

PHILIPS

Instructions for use
Mode d'emploi
Bedienungsanleitung
Istruzioni
Gebruiksaanwijzing
Instrucciones
Modo de emprego
Bruksanvisning
Käyttöohje
使用説明書

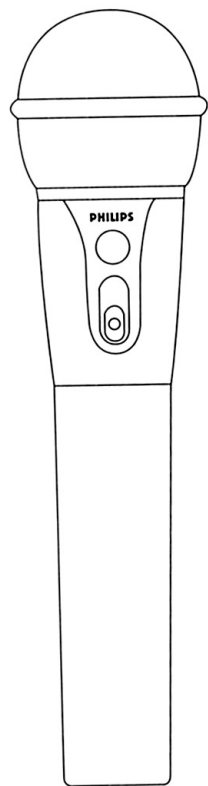
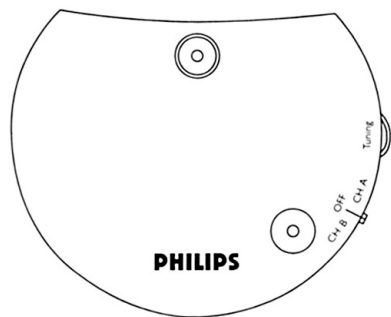

PHILIPS
SBC MC600

Explanation of Controls

SBC MC600

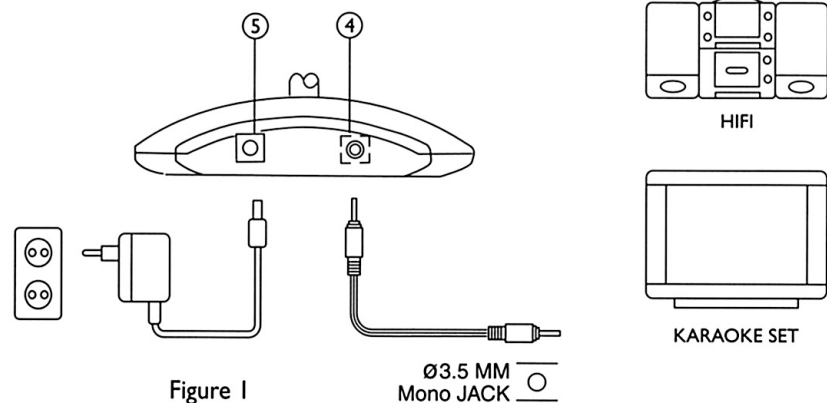

Figure 1

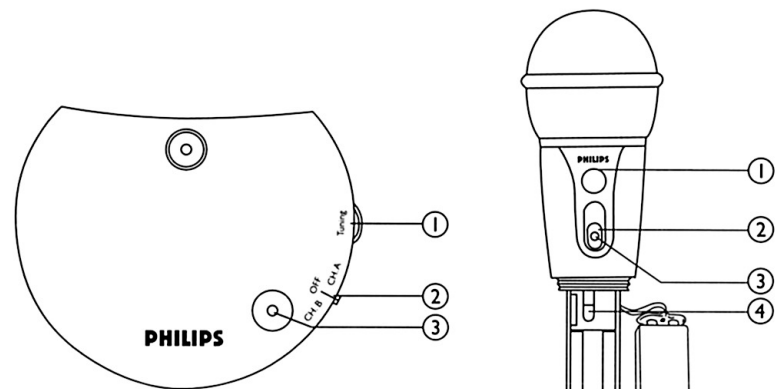

Figure 2

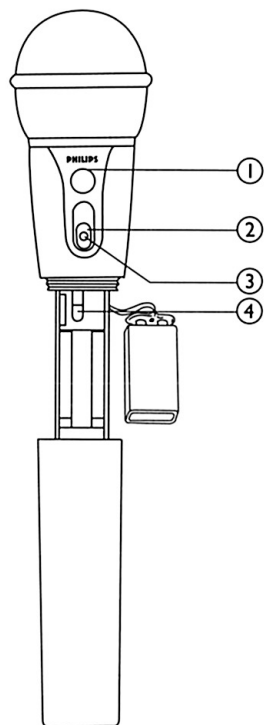

Figure 3

GB English

SBC MC600

Instruction for use

1. Introduction

Congratulations! You have just bought a most sophisticated RF/FM wireless microphone system. This system uses the latest RF/FM wireless technology to give you complete freedom of movement. No more inconvenience from cables and wires! To ensure you get the best performance from your RF/FM microphone system, please read this document carefully.

2. Features

- **Wireless transmission** - the FM microphone transmits signals to the FM microphone receiver without using any cables or wires. The FM microphone receiver is usually connected to a HiFi or karaoke system.
- **High-frequency radio system** - the FM microphone set uses a high radio frequency as the signal carrier, ensuring a very clear, sharp reception.
- **No line of sight required** - the FM microphone receiver is able to receive signals from the FM microphone even if the line of sight is blocked by doors, walls, windows, or any moving objects.
- **Up to 2 microphones operating at the same time** - 2 FM microphone sets can operate in the same room at the same time without interfering with each other.
- **Non rechargeable system** - the FM microphone operates on a 9 Volt non-rechargeable battery, and the FM microphone receiver is powered by a 12 Volt AC/DC power adapter. When the battery is empty, simply replace it with a new battery and continue playing. There is no need to wait for the battery to be recharged.

3. Components included

This FM microphone set contains the following components:

- FM microphone, SBC MC602
- FM microphone receiver, SBC MC605
- AC/DC adapter 12 Volt / 200 mA, SBC 6654
- HiFi audio cable
- 9 Volt battery 6LR61 type, SM544
- 3.5 mm to 6.3 mm mono jack adapter

4. Explanation of Controls

FM microphone

1. Tuning control knob
2. Power ON/OFF switch
3. Power ON and Battery indicator LED
4. Channel selection switch (CHA / CH B)

FM microphone receiver

1. Tuning control knob
2. Power ON/OFF switch and Channel selection switch (CHA / CH B)
3. Power ON indication LED
4. Microphone signal output
5. DC power input

5. Installation

- Please ensure that the rated voltage of the AC/DC power adapter is the same as the mains power supply before connecting the AC/DC power adapter to the mains power supply outlet.
- Insert the DC connector of the AC/DC power adapter into the 12 Volt DC input located at the rear of the FM microphone receiver, as shown in Figure 1.
- Connect the microphone output located at the rear of the FM microphone receiver to the microphone input of your HiFi or karaoke system using the HiFi audio cable, as shown in Figure 1.

GB English

SBC MC600

- Connect the 9 Volt battery to the battery snap inside the FM microphone and insert it into the battery compartment, as shown in Figure II.
- When using 2 sets of FM wireless microphones in the same room at the same time, switch one of the FM wireless microphone sets (i.e. microphone and receiver) to Channel B as shown in Figure III. The preset channel is Channel A.

6. Operation

- Switch power of the FM microphone to ON; the power indication LED lights up. If the power indication LED does not light, then the battery is empty and should be replaced.
Note: The preset channel is A by default. When using a second FM microphone set at the same time, switch the second FM microphone to Channel B.
- Switch power of the FM microphone receiver to CH A or CH B; the power indication LED lights up. The FM microphone receiver is turned ON power/channel selection switch is switched to either Channel A [CH A] or Channel B [CH B].
Note: The preset channel of the FM microphone is A by default. When using only one FM microphone set, ensure that Channel A is selected for the FM microphone receiver. When using a second FM microphone set at the same time, select Channel B for the second FM microphone receiver.
- Speak into the FM microphone and vary the tuning control on the FM microphone receiver until the signal is at its clearest. You can fine tune the signal using the tuning control on the FM microphone. While using the FM microphone, fine tuning may be required using the tuning control on the FM microphone.
- Adjust the volume of your HiFi or karaoke system to an acceptable level.

7. Specifications

System	: Radio Frequency (RF)
Carrier frequency	: Tunable Channel A - 434.4 to 434.7 MHz Channel B - 433.2 to 433.5 MHz
Modulation	: Frequency Modulation (FM)
Radiated output power	: 0.5 m Watt
Effective transmission range	: 15 - 30 meter, omni-directional (360°)
Microphone output level	: 8 m V
Power supply - FM microphone	: 9 Volt battery
Power supply - FM microphone receiver	: 12 Volt/200 mA DC
Frequency range (microphone)	: 80 - 16,000 Hz
Sensitivity (microphone)	: - 55 dB
Signal/Noise ratio	: > 60 dB
Distortion	: < 0.5% THD
Channel separation	: > 30 dB